

# The SOLAR Mission Tool - an integrated ops tool

Alejandro Fernández Sela<sup>1</sup>

*Space Applications Services, Zaventem, Belgium, B-1932*

Alice Michel<sup>2</sup>

*Belgian Institute for Space Aeronomy (IASB/BIRA), Belgium*

**The Belgian User Support and Operations Centre (B.USOC) has been successfully operating the Columbus external payload SOLAR for four years. This paper describes the evolution of the SOLAR Mission Tool from its origin to its future, focusing on the different development phases, and the positive impact that the tool had on quality assurance and process management. From a rudimentary set of Excel tools which merged and coupled different databases, and with the premise of facilitating the operator's life with a simple and clear interface, B.USOC has been able to considerably improve the quality of the day-to-day operations, planning and reporting activities. The tool is capable of extracting information from very different sources and presenting it visually to the operator. The success of this tool and the openness of the operations team to constructive changes, were influenced by the care that was applied during the development phase to the integration with the day-to-day operations. The effort and time invested on this long-term mission have resulted in a complete tool which assures the quality, facilitates the daily tasks, prepares valuable reports, and provides the operator and all other stakeholders with an extensive overview of the past, present, and future activities of the payload.**

## I. Introduction: the SOLAR mission

**T**HE ESA SOLAR payload onboard the International Space Station (ISS) has been successfully launched on February 7th, 2008 and is operational since February 14<sup>th</sup> of the same year. It is installed on the Columbus External Payload Facility (CEPF) and mounted on a Columbus External Payload Adapter (CEPA). SOLAR was designed to operate for 1.5 years, but a mission extension has been approved, guaranteeing the mission to last until at least 2013. The primary objective of the SOLAR mission is the monitoring of solar irradiance (Thuillier, Frohlich, & Schmidtke, 1999; Schmidtke, Frohlich, & Thuillier, 2006). The total and spectral solar irradiance are measured by three instruments, all together covering a wavelength range from the near infrared (IR) to the extreme ultra-violet (EUV) part of the electromagnetic spectrum, in which 99% of the solar energy is emitted. The different scientific instruments are:

- 1) SOVIM (Solar Variability and Irradiance Monitor): which measures the total solar irradiance (TSI) and the spectral solar irradiance (SSI) at three different wavelengths.
- 2) SOLSPEC (SOLar SPECTrum): which consists of three spectrometers measuring the SSI in the wavelength range between 165 to 3080nm (Thuillier, et al., 2009).
- 3) SOLACES (SOLar Auto-Calibrating EUV/UV Spectrometers): which uses four spectrometers to measure the EUV/UV spectral emission, covering the wavelength range between 16 to 220nm, with a spectral resolution from 0.5 to 2.3nm. (Schmidtke, et al., 2006)

---

<sup>1</sup> Operations Engineer, Operations Group, Space Applications Services, Leuvensesteenweg 325, 1932 Zaventem, Belgium, not an AIAA member.

<sup>2</sup> B.USOC ISS Operations BIRA Project Manager, IASB, Avenue Circulaire 3, 1180 Bruxelles, Belgium, and not an AIAA member.

The three instruments are mounted on the Course Pointing Device (CPD), a movable control system that allows the tracking of the Sun. A schematic of the system is displayed in Figure 1.

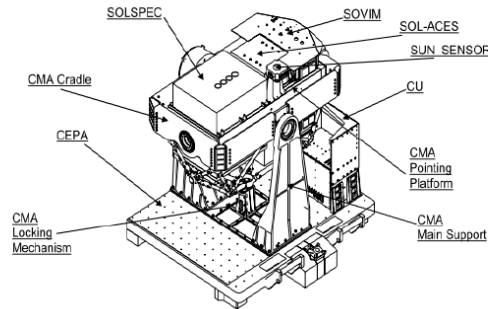

**Figure 1. Overview of the SOLAR payload**

The SOLAR payload instruments are positioned such that the detectors are pointing towards the ISS zenith direction (i.e. away from the Earth). Due to the precession of the ISS orbit and due to the mechanical constraints of the SOLAR CPD, the Sun cannot continuously be observed by SOLAR. The visibility is mainly dependent on the “ISS beta angle”, which expresses the position of the ISS orbital plane with respect to the Sun vector. This angle varies slowly over time between a value of  $-74$  and  $+74$  degrees, depending on the time of the year. In order to make solar observations, the payload has to perform a rotation to compensate for the beta-angle and another rotation to compensate for the apparent motion of the Sun. In the nominal ISS attitude, SOLAR observations are only possible when the beta angle is between  $-24$  and  $+24$  degrees, due to the mechanical limits of the rotation around the indexation axis of the CPD. In practice, this leads to the so called Sun Visibility Window (SVW), during which SOLAR can make scientific measurements. The typical duration of a SVW is 10 to 15 days. As the de-rotation angle of the CPD is limited to 40 degrees, the Sun cannot be tracked during a complete ISS day, but only for a period of about 20 minutes during a SVW.

The B.USOC team has been operating the SOLAR payload since its launch. Each of the instruments has different operational constraints and specific calibration requirements. Because of the long-term perspective of the mission, B.USOC has invested in creating a high-level operations tool that allows an efficient handling of the different payload activities. The SOLAR operations tool adds significant value to the operations team and contributes to the successful management of the SOLAR mission. The structure of the paper is as follows: in section two, a brief summary of some of the daily operations activities to be executed by B.USOC is presented; section three describes the development of the improved operations tool and its capabilities and advantages are described; the conclusions of this paper are summarized in the closing section.

## **II. Daily operations**

As an operations team B.USOC is responsible for the correct planning and execution of the scientific measurements. Typical operations to be performed by the B.USOC team are:

- 1) File transfer activities
- 2) Activity planning and execution
- 3) Reporting of the daily operations
- 4) Timeline reviews

The three instruments do not necessarily conduct their measurements simultaneously and also the calibration periods are different for each instrument. Moreover, environmental constraints, such as the passage through the South Atlantic Anomaly or thruster firings need to be taken into account when planning the specific activities. After the first two years of the SOLAR mission, the amount of information to be managed by the operations team started to be critical. The operational constraints on each instrument started to grow due to some anomalies, and due to specific requests from the scientists. In addition, the B.USOC team as well included additional preconditions in order to optimise the science measuring windows, increasing the complexity of operations and the risk of errors (Wislez, Hoppenbrouwers, & Michel, 2010),

### III. The improved operations tool

In order to improve the daily operations, the B.USOC Operations team started building a complete tool based on the integration of the routine tasks and the improvement of each process. This system was based on an Excel file with several interconnected worksheet tabs, and grew as all the different processes matured. It was updated based on the different ideas coming from the team.

#### A. File transfer

A critical activity of the operations is the file transfer to the Columbus Mass Memory Unit (MMU), from where the files are uplinked to the SOLAR payload. In case such a file transfer fails, as has happened several times, the traceability of which files, and where were they located, is of essential relevance for the operator. Originally, a text file was supposed to be updated each time a file was transferred, but no tracking was kept and, sometimes, the text file was outdated, which is obviously detrimental for efficient operations. To improve the file transfer operations, an Excel database was created with all the transfer steps on it. This database was updated during each up-link activity, and each new file was recorded on it. In case a file was outdated or not required anymore, this information was added to the database and the information was available for all the operators. A schematic of this activity is shown in Figure 2

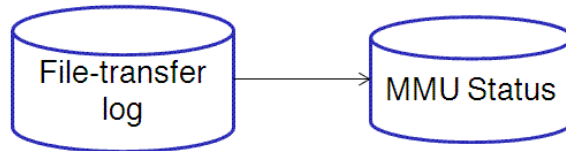

**Figure 2. The tool keeps traces of all the uplinked files to SOLAR (Filetransfer log) and the MMU positions utilisation (MMU Status)**

#### B. Science planning

Science planning has to take into account the different activities planned on the ISS that might influence the payload measurements, such as the environmental constraints, the periods with loss of signal, etc. Science activities can be executed manually or using Command Schedules (CS), which are files that contain sequences of commands required to execute measurements. Since the planned activities are therefore linked to the available files on the MMU, a natural next step was to merge the Command Schedule (CS) planning with the file transfer spreadsheet. In addition, some of the planning constraints mentioned above were implemented in the database. For configuration control, each constraint was added in a different spreadsheet, and next everything was merged in a single tab. Different activities are marked by automatic colour coding, making science planning much easier and more organised. The operator is able to see in a single glance the complete sequence of activities and the measurement constraints on an orbit basis. In addition, it is also possible to track which files are needed for which day, facilitating the file transfer process. A schematic overview of the process is shown in Figure 3.

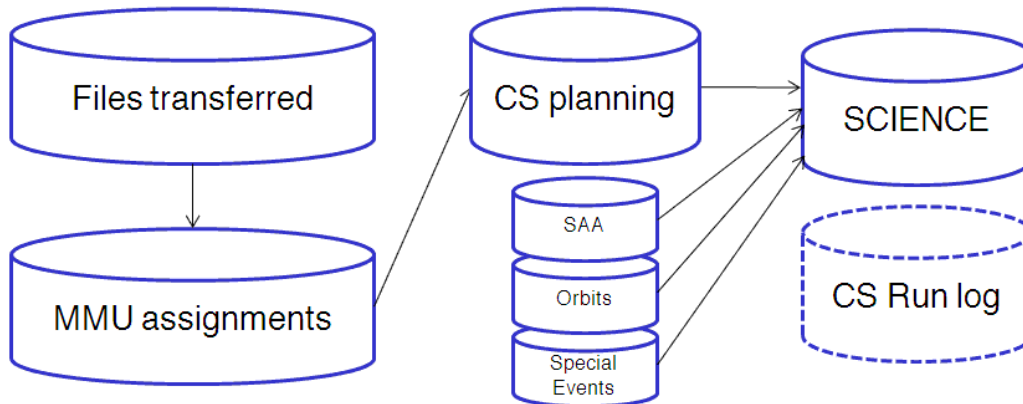

**Figure 3. The occupied positions on the MMU are automatically registered in the file transfer log**

### C. Daily Operations Report

The Daily Operations Report (DOR), which as the name suggests is generated daily, contains all the information of the executed and planned activities, as well as any interesting information like anomalies or the ISS status. Since the scientific measurements are the core payload activities, it was decided to use the science schedule as the backbone for the DOR. Another important aspect of the DOR is the reporting and management of any changes to the original schedule. In the early days of the SOLAR mission the DOR was generated manually, by checking all the available resources and performing a series of *copy-paste* actions. As the amount information to process was ever growing, the generation of the DOR became a time demanding daily task. Moreover, this *modus operandi* was not only frustrating, but also quite error-prone and the real-time re-planning started to be a potential source of errors.

As the mission evolved and the operations were more and more bound by constraints, the optimisation of the *copy-paste* activities gained priority. Since the planning tool contained most of the inputs for the DOR, the planning tool was adapted such that it could automatically generate the DOR, including only the information essential for the daily activities reporting. The integration of the DOR in the planning tool was a challenging project, as this report contains past, present, and future data from different sources. An example of the DOR is represented on Figure 4 (Appendix C). The complexity of the data structure of the DOR is illustrated in Figure 5.

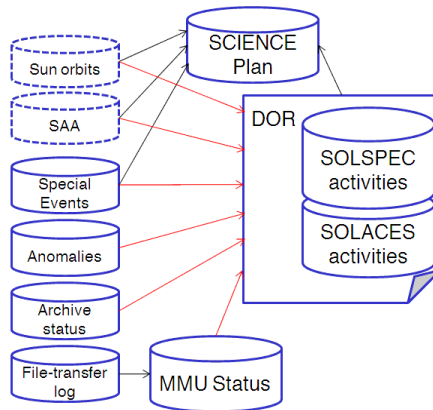

Figure 4. Databases connected to the DOR

### D. The long term mission overview

At this stage, all the constraints and activities had been collected in the DOR, however this document did not yet give a clear overview of the complete mission. A detailed overview of payload performance is needed for the analysis of anomalies, or to give feedback to the scientists. For that reason, the functionality of the planning tool has been extended with the objective to collect information on a daily basis. Statistics can easily be extracted from this tool, as well as the correlation between events and anomalies. Figure 6 represents the updates performed on the tool with the addition of the *Main* tab. This tab contains information regarding the activities, anomalies and status of the mission on a daily bases. It is also connected to the DOR.

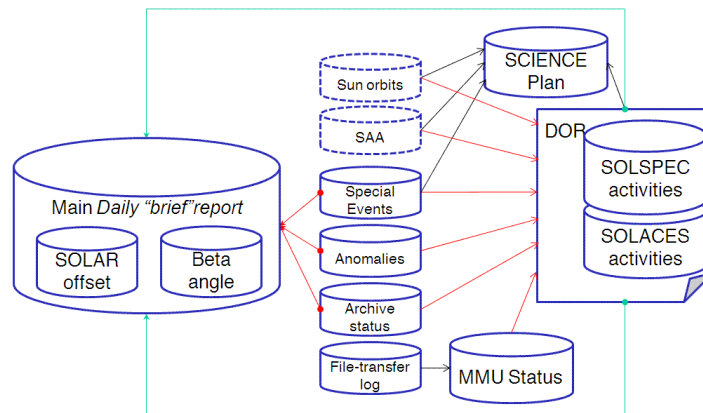

Figure 5. Long term mission overview tab integration

### E. Timeline reviews, changing processes

Another important activity on each ISS mission is the timeline review. For the real-time reviews, a process that starts one week before the actual activity, each team follows its well-documented procedure. In case of a short-term mission, it might not be worth spending time on the development of a specific tool to schedule a couple of activities. However, for a long-term mission such as SOLAR with many different activities scheduled, this process becomes a time consuming task where changes in the planning can easily be missed. For such a mission, the handover between one shift and the following ones is critical. The process of manual revision and handwritten log-files, which works properly for short-term missions with only few activities, is inefficient for a mission like SOLAR. The timeline review process was therefore integrated into the daily operations tool as shown in Figure 7.

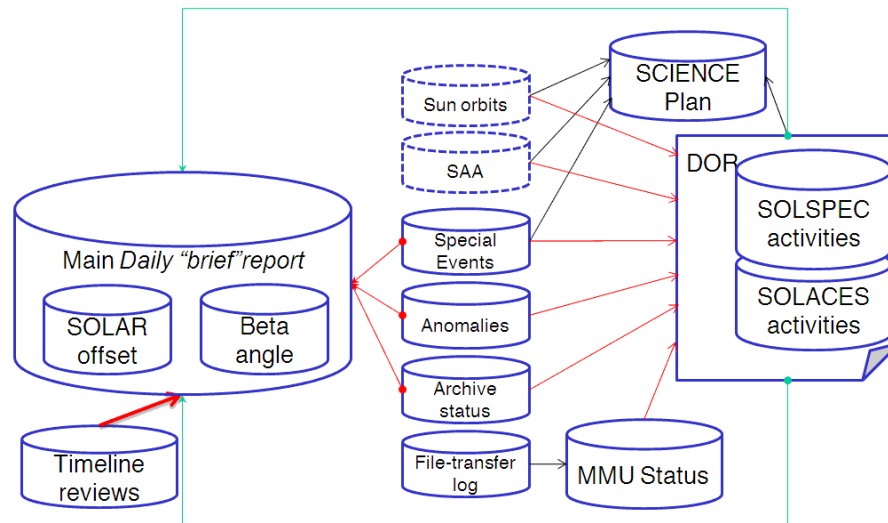

Figure 6. Final phase of the SOLAR Mission tool

### F. Current status and future development

The tool was proven successful, and very powerful, but it was not yet enough for a long term mission, furthermore manually updating the external constraints was time-consuming and could only be performed by an experienced excel user. Using the acquired management know-how, and with the same objectives as the first version, a new tool was created In parallel to the SOLAR Mission Tool. The core of this new tool is a predictor tool developed in order to identify the tracking information and the actual start of the measuring periods. This is an additional source of information greatly appreciated for SOLAR operations and an excellent start point for the new development.

The tool was decided to be based on PHP. The objective was to autonomously connect the different external sources of information, and also to provide all the information on a more intuitive and attractive way for the team together with complementary graphics.

Storing data on a tool, and being able to browse through it, might not be considered a difficult task, but the data itself does not mean anything if there is not anyone behind to interpret it. Assuming that a skilled team is behind that data, the current development status could be sufficient, but for Real Time operations, a fast interpretation of the data is typically crucial for mission success. Even though the SOLAR Mission Tool contained some decision aids and intelligence behind, the Predictor Tool contains much more resources. In fact, it was conceived as a knowledge management tool tailored to daily real time operations environment.

In addition to all the features from the SOLAR Mission Tool, the Predictor Tool is able to anticipate possible conflicts, and to generate warnings for the operator. Enhancements and modifications are continuously added to improve efficiency and accuracy. This continuous improvement philosophy which has been applied from the beginning of the mission has generated a large amount of requests for the Predictor Tool. Those improvements which were too hard to implement on the SOLAR Mission Tool, were postponed and integrated on the new tool. In this way, the new tool's architecture was already defined taking these inputs into account.

#### **IV. Conclusion**

During long-term space missions, the way multiple sources of information are presented and made available for the payload operators is crucial to ensure the success of the mission. The amount of tools used to interface with the different stakeholders in human space flight is large, and still growing, and to keep track of every single item relevant to a specific payload can turn out to be a complex exercise. This is especially true for the planning operations, and the awareness of changes might become difficult to reach for a 24h/7 operations team. In such a situation, an integrated operations tool is required, allowing the operator to focus on additional tasks which give a truly added value to the mission output, rather than spending the available resources on *copy-paste* tasks, which can lead to human errors from multi handling. The effort and time invested on this long-term mission have resulted in a complete operations tool, which assures high quality, facilitates the daily tasks, prepares valuable reports, and provides the operator and all other stakeholders with an extensive overview of the past, present, and future activities of the payload. The final SOLAR Mission Tool is extremely intuitive and user friendly and contributes to the highly reliable service provided by the B.USOC team.

**Appendix A**  
**Acronym List**

<b>B.USOC</b>	Belgian User Support and Operations team
<b>CEPA</b>	Columbus External Payload Adapter
<b>CEPF</b>	Columbus External Payload Facility
<b>CPD</b>	Course Pointing Device
<b>CS</b>	Command Schedule
<b>DOR</b>	Daily Operations Report
<b>EUV</b>	Extreme ultra-violet
<b>IR</b>	Infra Red
<b>ISS</b>	International Space Station
<b>MMU</b>	Columbus memory unit
<b>PHP</b>	Hypertext Preprocessor (HTML-embedded scripting language)
<b>SAA</b>	South Atlantic Anomaly
<b>SOLACES</b>	SOLar Auto-Calibrating EUV/UV Spectrometers
<b>SOLSPEC</b>	SOLar SPECTrum
<b>SOVIM</b>	SOLar Variability and Irradiance Monitor
<b>SSI</b>	Spectral solar irradiance
<b>SVW</b>	Sun Visibility Window
<b>TSI</b>	Total solar irradiance

## Appendix B

### Acknowledgments

The authors thank the European Space Agency (ESA) Directorate of Human Spaceflight (D/HSF) (ESA Exploitation Program) and the Belgian Science Policy Office (BELSPO) (ESA Prodex and other programs) for their funding. B.USOC is part of the Services & Operations Division of the Belgian Institute for Space Aeronomy (BISA).

Further the authors thank the ESA Payload Operations Management, the ESA Mission Science Office (ESA-MSO), the European Astronaut Centre (EAC), the Columbus Control Centre Flight Control Team (Col-CC FCT), the SOLAR Payload Developers, the Science Teams, and the B.USOC Operator team for the good collaboration and support.

Also a special word of thanks to the B.USOC management and Space Applications Services management for their support and for providing the budget and personnel for the activities.

### References

- Schmidtke, G., Brunner, R., Eberhard, D., Halford, B., Klocke, U., Knothe, M., et al. (2006). SOL-ACES: Auto-calibrating EUV/UV spectrometers for measurements onboard the International Space Station. *Advances in Space Research*, 37, 273-287.
- Schmidtke, G., Frohlich, C., & Thuillier, G. (2006). ISS-SOLAR: Total (TSI) and spectral (SSI) irradiance measurements. *Advances in Space Research*, 37, 255-264.
- Thuillier, G., Foujols, T., Bolsée, D., Gillotay, D., Hersé, M., Peetermans, W., et al. (2009). SOLAR/SOLSPEC: Scientific Objectives, Instrument Performance and Its Absolute Calibration Using a Blackbody as Primary Standard Source. *Solar Physics*, 257, 185-213.
- Thuillier, G., Frohlich, C., & Schmidtke, G. (1999). Spectral and total solar irradiance measurements on board the international space station. *Utilisation of the International Space station, Proceedings of 2nd European Symposium* (pp. 605-611). Noordwijk, The Netherlands: ESTEC.
- Wislez, J., Hoppenbrouwers, T., & Michel, A. (2010). *Dealing with Operations Constraints for External Payloads*. Brussels: AIAA-2010-2056, SpaceOps 2010 Conference.



## Appendix C DOR



SOLAR DOR 2010

GMT 244



Sun visibility window #32	
Start date	End date
03/09/2010	14/09/2010

SOLACES offset	0
SOLSPEC offset	0
Total lost orbits	0
Anomalies	0

SOLAR ASW	4.8
COL SW Cycle	12
Date	1-Sep-2010

--

SOLAR PLATFORM ACTIVITIES PERFORMED DURING THE COVERED PERIOD		
DOY	Hour	Activity description

SOLACES Activities						
Activity/CS	Orbits	DOY	Time	Real start proposed start	DOY	
IAC35.DAT	11	246		3/9/10 0:00	GMT 246	ST >= 7min.
IASF43.DAT	2			3/9/10 16:30	GMT 246	ST >= 20min.
IAC33.DAT	6			3/9/10 18:40	GMT 246	ST >= 7min.
IAC32.DAT	6			7/9/10 0:27	GMT 250	ST >= 7min.
IASF41.DAT	2			7/9/10 14:33	GMT 250	ST >= 20min.
IAC32.DAT	11			10/9/10 17:25	GMT 250	ST >= 7min.
IASF42.DAT	5			20/9/10 12:11	GMT 255	ST >= 20min.
IAC24.DAT	2			9/9/10 17:47	GMT 250	ST >= 5min.
IASF41.DAT	2			9/9/10 20:44	GMT 250	ST >= 20min. pressure Imv34 < 10 mbar
IAC33.DAT	6			9/9/10 23:00	GMT 250	ST >= 7min.
IASF33.DAT	2			9/9/10 0:35	GMT 250	ST >= 20min. 2nd orbit: criss-cross
IAC35.DAT	3			9/9/10 11:57	GMT 250	ST >= 20min. 3rd orbit: criss-cross
IASF41.DAT	2			9/9/10 18:30	GMT 250	ST >= 20min.
IAC32.DAT	11			10/9/10 19:23	GMT 250	ST >= 7min.
IASF42.DAT	2			10/9/10 12:11	GMT 255	ST >= 20min.
IAC32.DAT	11			10/9/10 19:10	GMT 250	ST >= 7min.
IASF41.DAT	2			13/9/10 0:30	GMT 256	ST >= 20min.

SOLSPEC Activities			
Activities	DOY	Time	Comments
SSCAL5.DAT		GMT 246	
SSMGCA3.DAT		GMT 246	
SSSOF.DAT		GMT 247	
SSSUV1.DAT		GMT 253	
SSSOF.DAT		GMT 254	
SSCAL5.DAT		GMT 254	
SSMGCA3.DAT		GMT 254	
SSCAL10.DAT		GMT 255	
SSSOF.DAT		GMT 256	
SSCAL9.DAT		GMT 256	

ON SOLAR
ONLY on MMU
File not yet transferred to SOLAR
Special event during activity. Needs re-planning

ON SOLAR
ONLY on MMU
File needs other files
File not yet transferred to SOLAR or manual activity

SPECIAL EVENTS							
# Lost orbits	Start date			End date			Events
	DOY	Hour	info only	DOY	Hour	info only	
	251	13:45	08/09/2010	251	16:50	08/09/2010	Solar Array Efficiency Test
	253	10:25	10/09/2010	253	14:00	10/09/2010	39P Docking
	257	19:36	14/09/2010	257	20:30	14/09/2010	WIS Thruster Test
	258	7:25	15/09/2010	258	10:00	15/09/2010	39P Reboost
	267	0:30	24/09/2010	267	5:10	24/09/2010	2S Undocking and Relaxation Experiments

Anomalies					
# Lost orbits	DOY	CFN	AR/TT	Title/Description	Recovery actions executed

Missing data			
Period	Type	Comments/References	Recovery status
2010/189-201	microgap outside science	Minor gaps. Not worth requesting from NASA.	permanent loss of no-science TM
2010/211-239	microgap outside science	Minor gaps. Not worth requesting from NASA.	permanent loss of no-science TM
2010/208	gap outside science	gap outside science data of SOLSPEC calibration	successfully filled

Figure 7. Daily Operations Report layout